

Part No:	GH-201-L
Holding Capacity:	27Kg
Bar Opens:	90°
Handle Opens:	75°
Weight:	0.03Kg
Spindle Supplied:	SA-042007(Nylon)
Flanged Washers:	FW-080

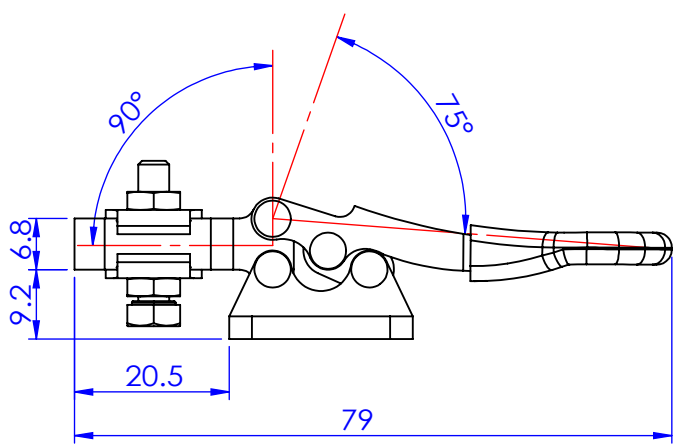
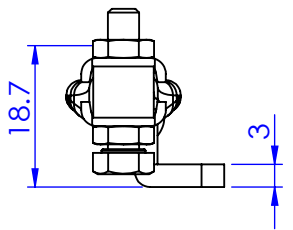
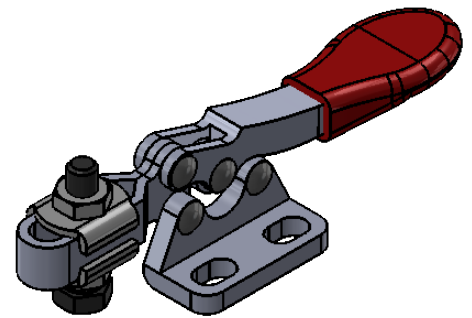
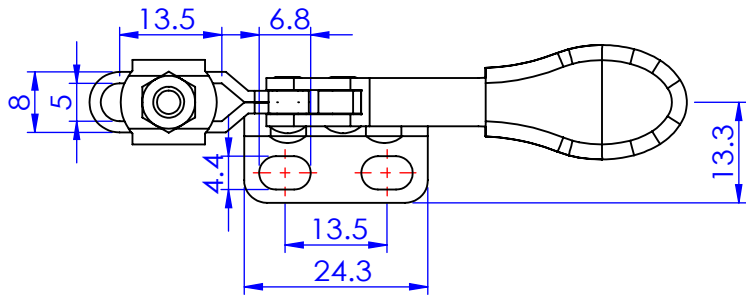

Unit:mm  
Scale: 1:1

 <b>Good Hand Enterprise Co., Ltd</b>	
TITLE:	
DWG NO.	GH-201-L
	A4