

Part No:	GH-14502-B
Holding Capacity:	450 Kg
Bar Opens:	90°/125°
Handle Opens:	70°/85°
Weight:	1.3 Kg
Spindle Supplied:	SA-121017
Flanged Washers:	FW-120

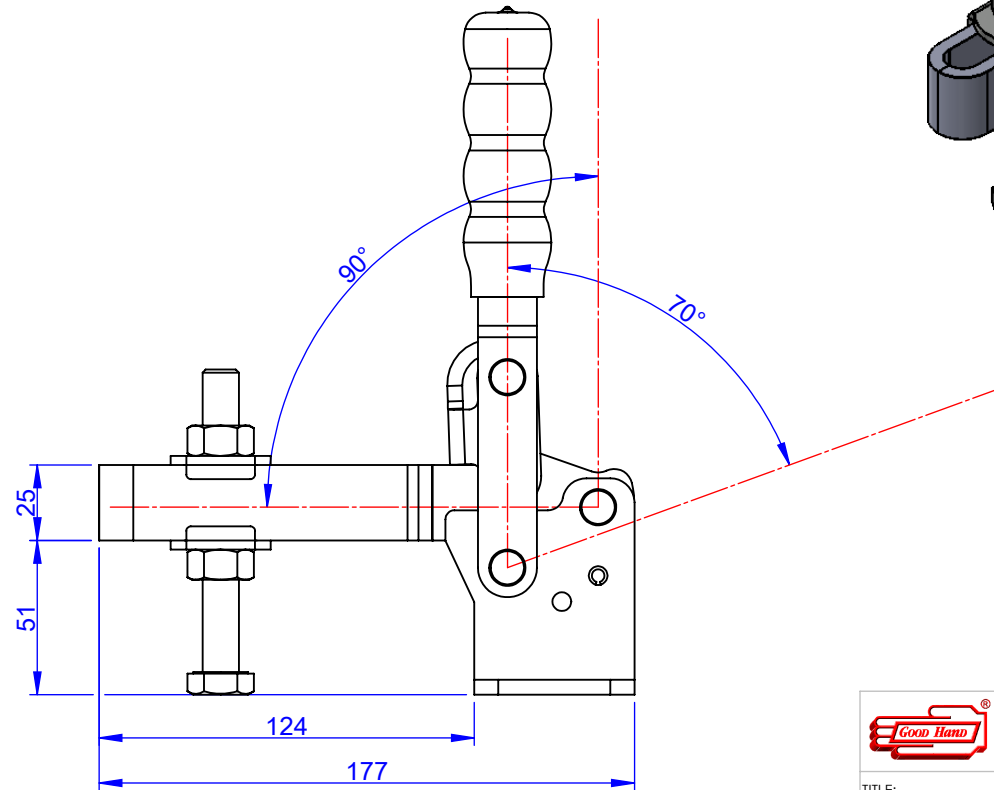
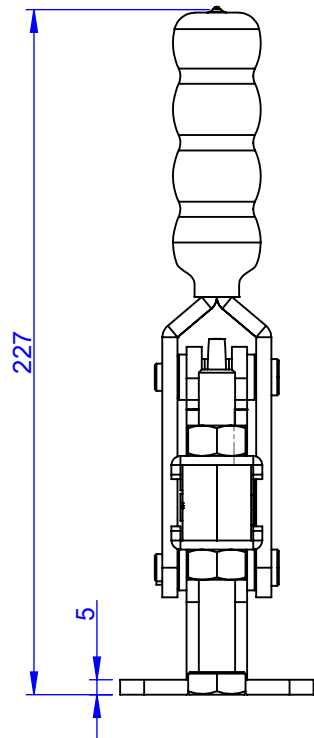
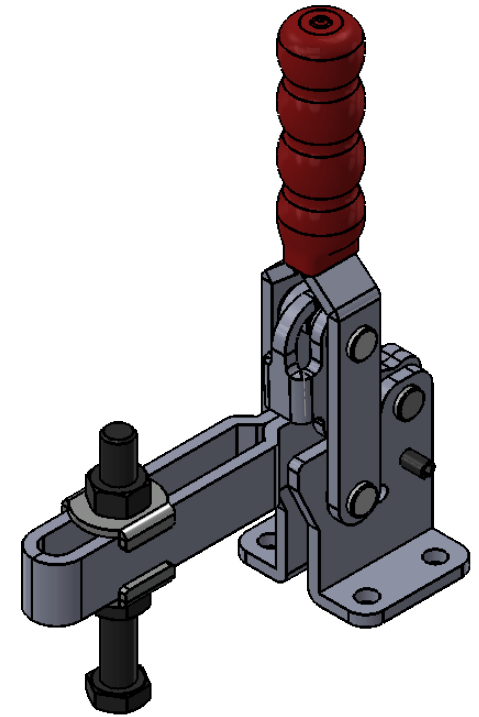
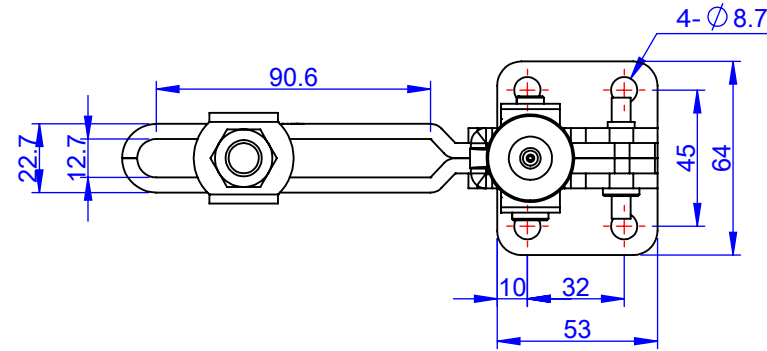

Drawing Scale:1:2.5
Unit:mm

 **Good Hand Enterprise Co., Ltd**

TITLE:

DWG NO.

GH-14502-B

A4