

Part No:	GH-106-B
Holding Capacity:	100Kg
Bar Opens:	114°
Handle Opens:	77°
Weight:	0.163Kg
Spindle Supplied:	FC-064410
Flanged Washers:	FW-142

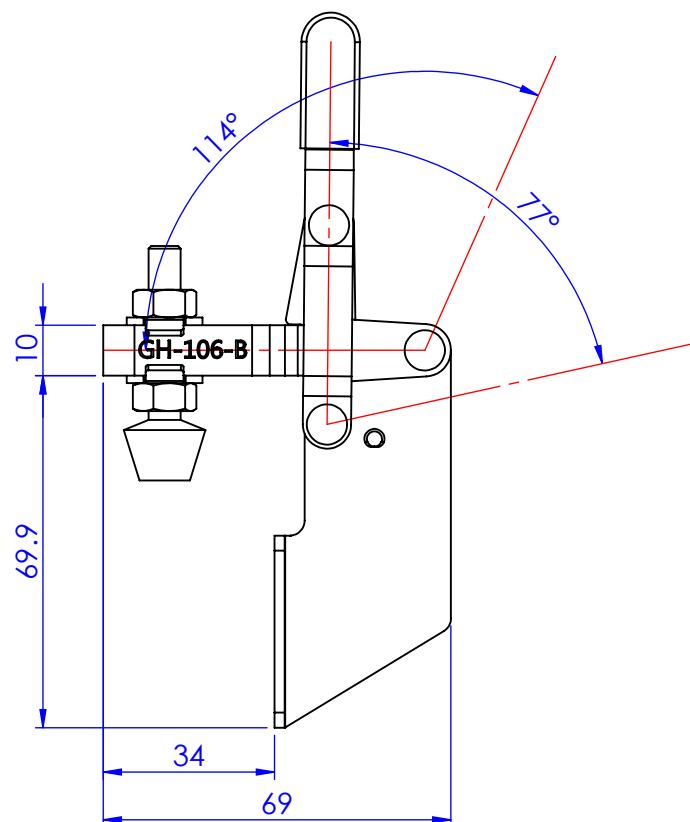
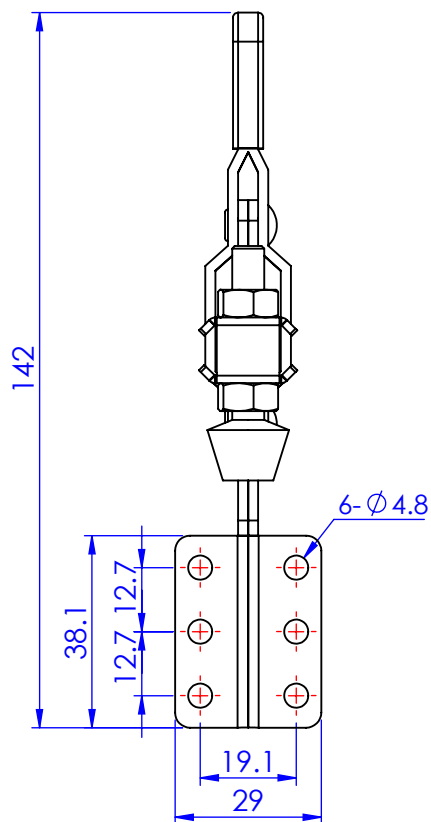
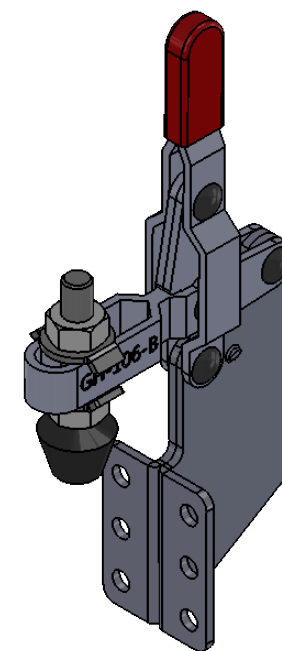
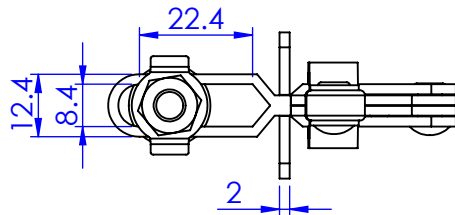

Unit:mm
Scale: 1:1.5

 **Good Hand Enterprise Co., Ltd**

TITLE:		
DWG NO.	GH-106-B	A4