

Part No:	GH-101-J
Holding Capacity:	550Kg
Bar Opens:	100° /140°
Handle Opens:	50° /60°
Weight:	2.504Kg
Spindle Supplied:	SA-161520
Flanged Washers:	FW-580

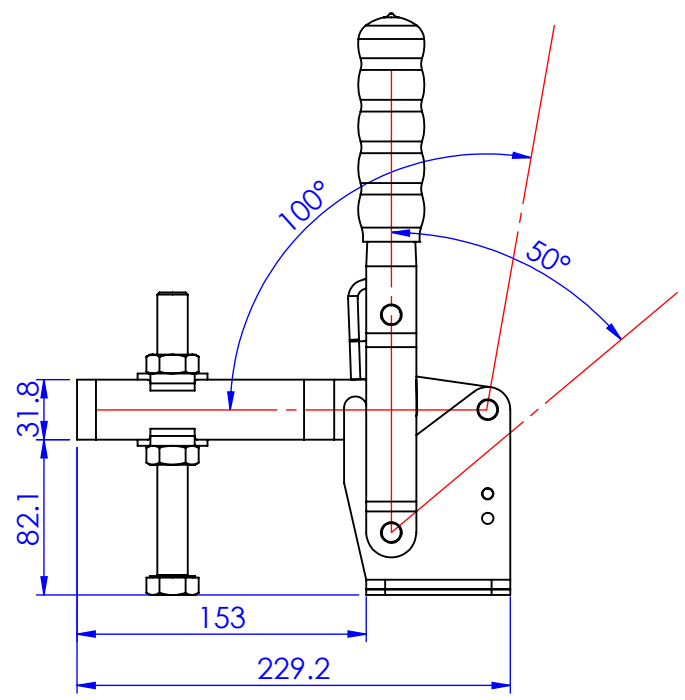
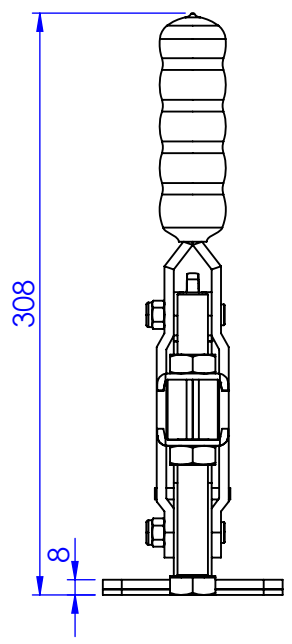
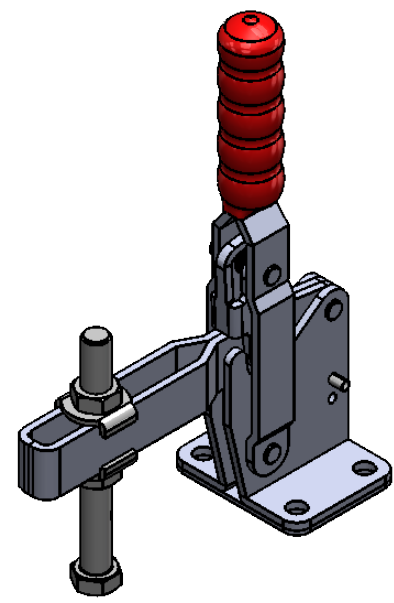
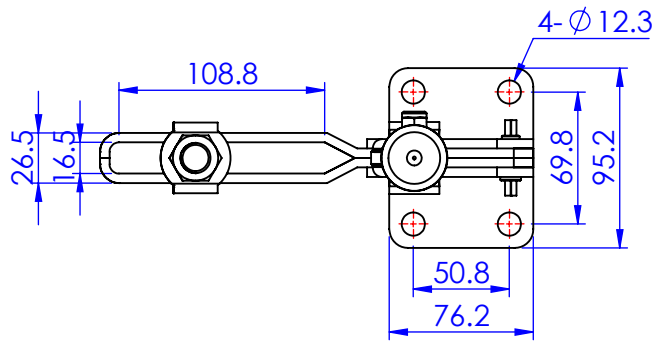

Unit:mm
Scale: 1:4

 **Good Hand Enterprise Co., Ltd**

TITLE:

DWG NO. GH-101-J A4