

Part No:	GH-101-ASS
Holding Capacity:	50Kg
Bar Opens:	100°
Handle Opens:	56°
Weight:	0.064Kg
Spindle Supplied:	SA-053008-SS
Flanged Washers:	FW-100-SS

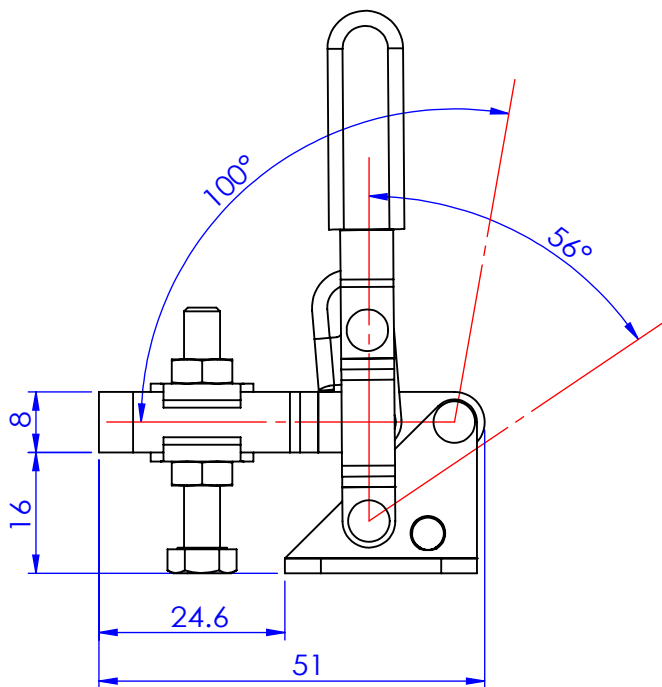

Unit:mm

Scale: 1:1

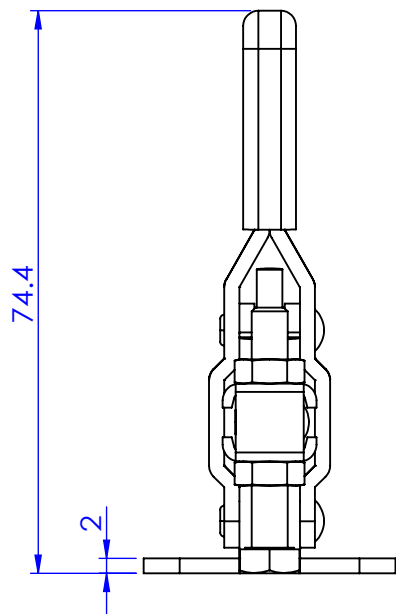
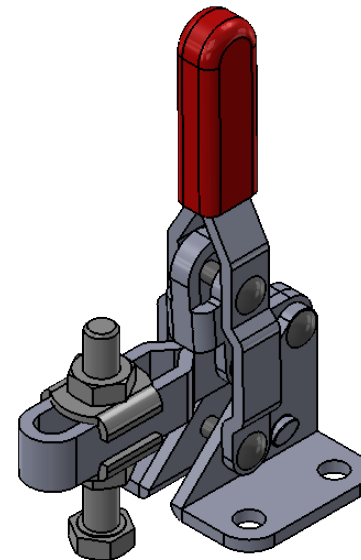
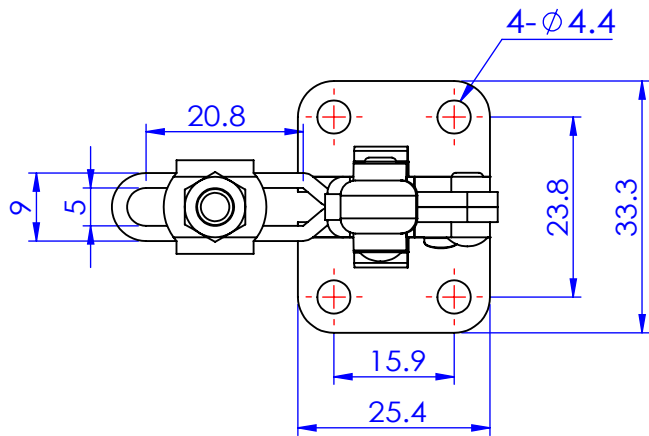

Good Hand Enterprise Co., Ltd

TITLE:

DWG NO.

GH-101-ASS

A4