

Part No:	GH-101-AL
Holding Capacity:	50Kg
Bar Opens:	100°
Handle Opens:	56°
Weight:	0.075Kg
Spindle Supplied:	FC-053708-LP
Flanged Washers:	FW-100

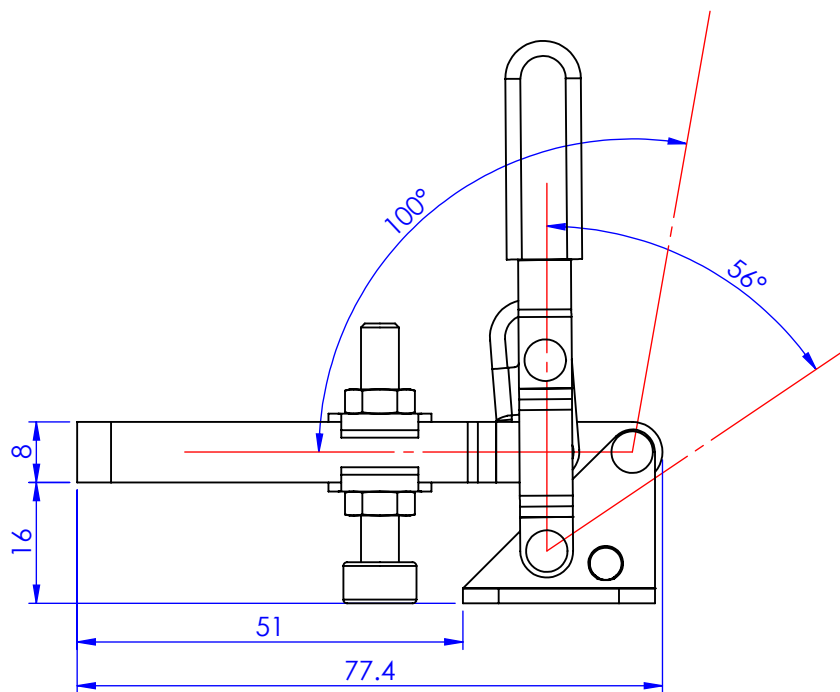
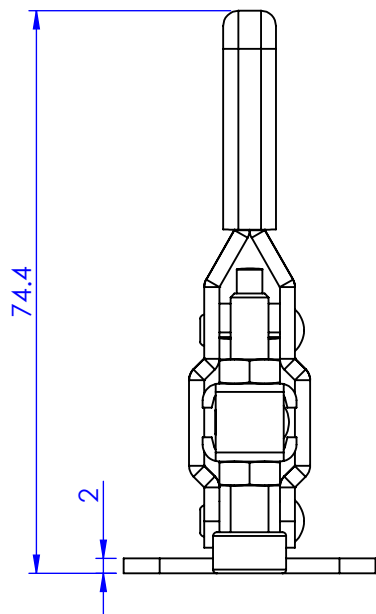
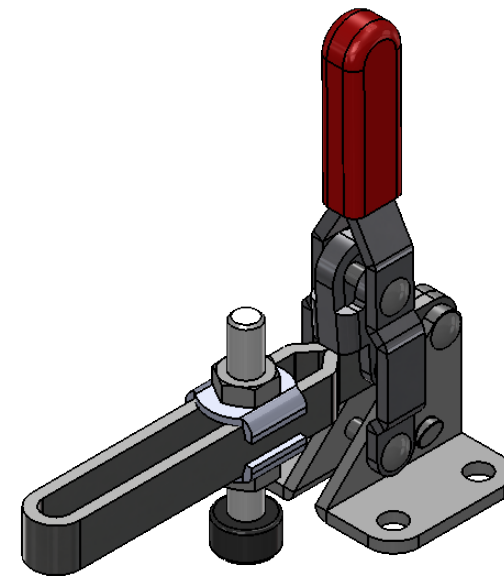
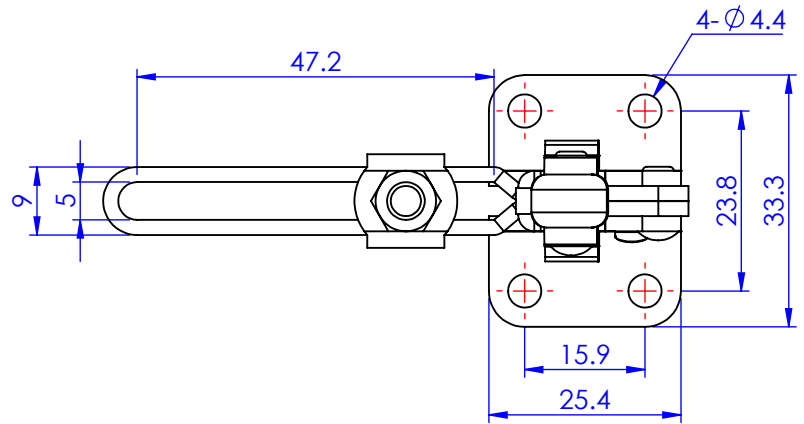

Unit:mm

Scale: 1:1

 **Good Hand Enterprise Co., Ltd**

TITLE:

DWG NO. GH-101-AL A4