

Part No:	GH-101-A
Holding Capacity:	50Kg
Bar Opens:	100°
Handle Opens:	56°
Weight:	0.064Kg
Spindle Supplied:	FC-053708-LP
Flanged Washers:	FW-100

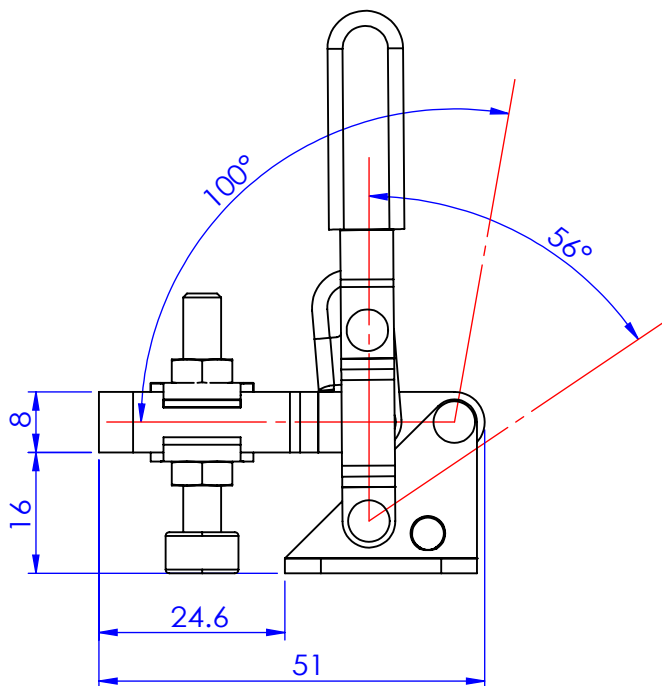

Unit:mm

Scale: 1:1

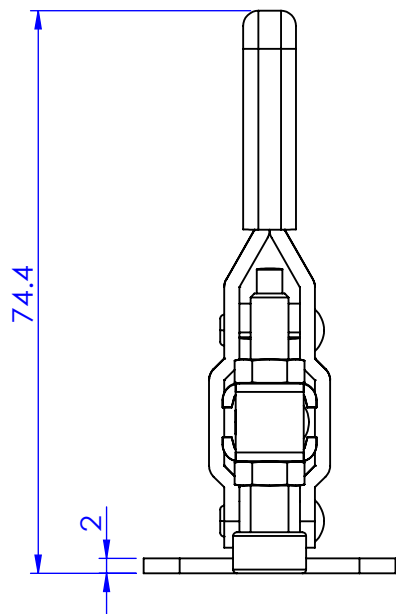
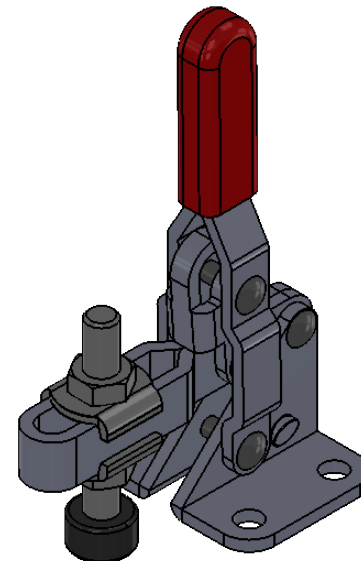
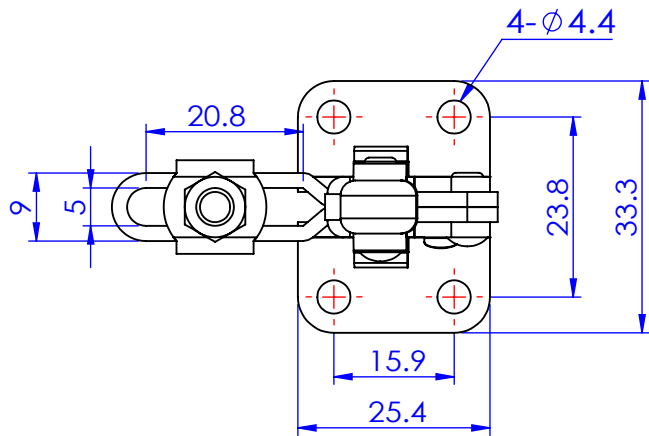

Good Hand Enterprise Co., Ltd

TITLE:

DWG NO.

GH-101-A

A4