

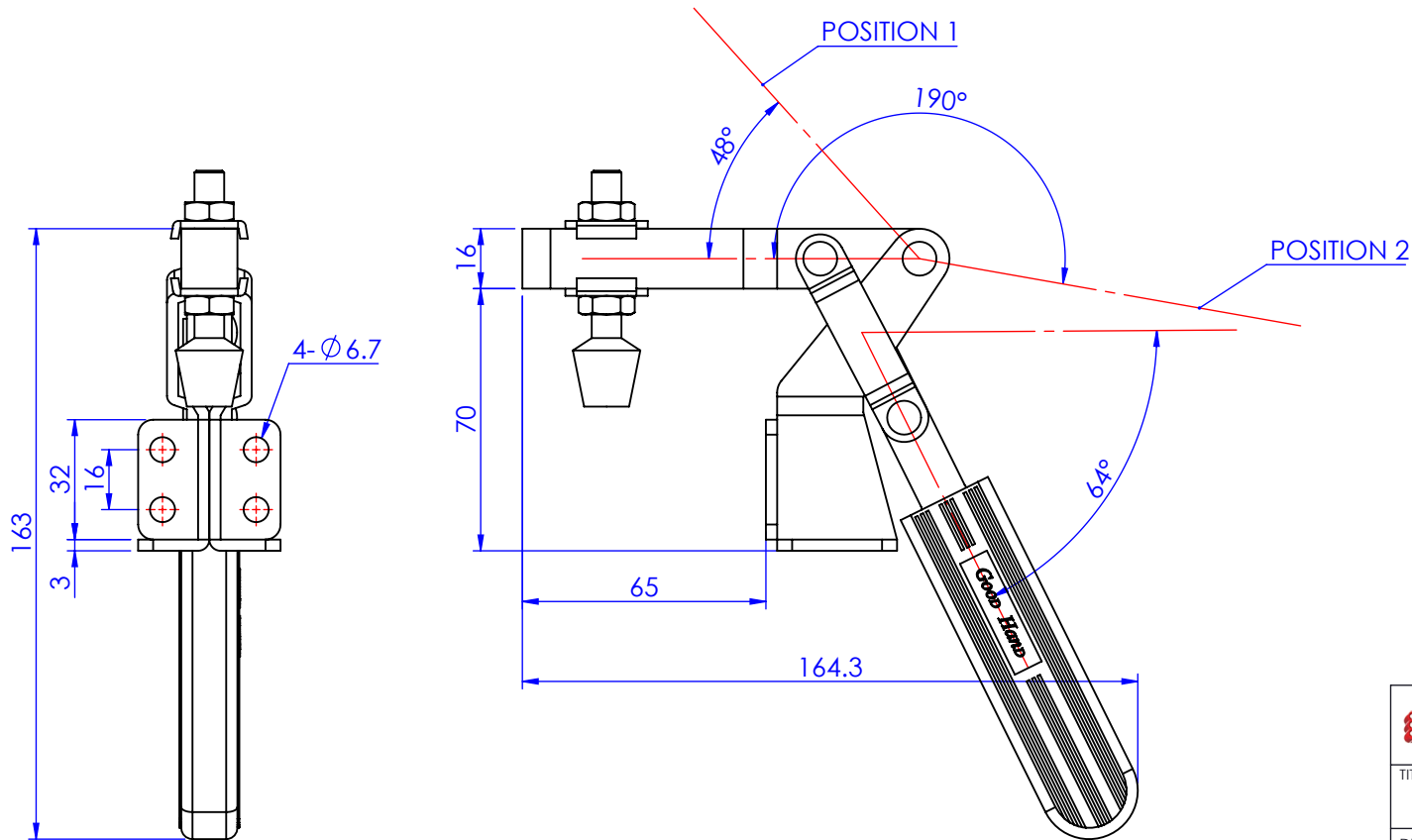

Part No:	GH-20820
Holding Capacity:	100Kg
Bar Opens:	190°
Handle Opens:	64°
Weight:	0.42Kg
Spindle Supplied:	FC-086312
Flanged Washers:	FW-516

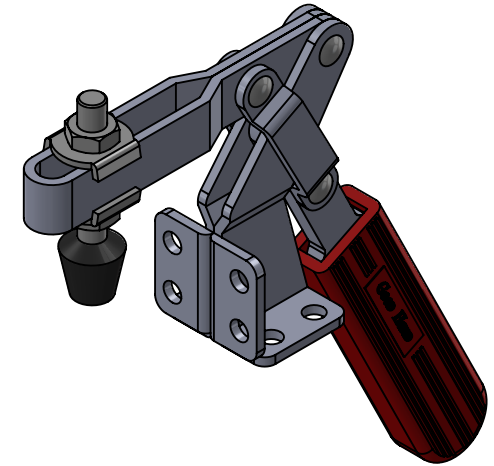
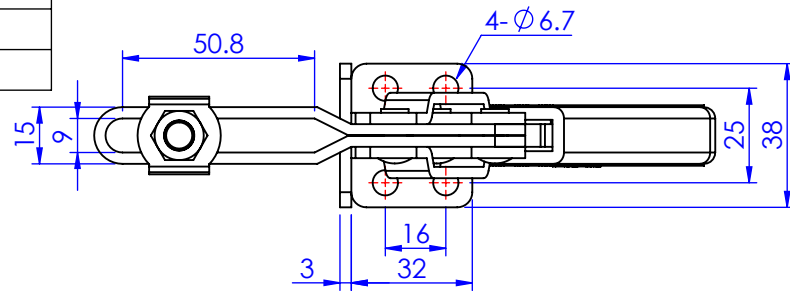

Unit:mm

Scale: 1:2

 Good Hand Enterprise Co., Ltd	
TITLE:	
DWG NO.	GH-20820
	A4